



SIGNATURE LINE FLOODED T-125

1200 CYCLES @ 50 % DOD

• TRULY DEEP CYCLE – MAXGUARD T2

- BCI Group GC2, 6V
- Reserve Capacity [Ah@20hr rate]: 240
- Reserve Capacity [Ah@100hr rate]: 266
- Energy [kWh]: 1.60
- Weight: 66 lbs.
- Length: 10.30 in (262 mm)
- Width: 7.06 in (179 mm)
- Height: 10.73 in (273 mm)
- ELPT / EHPT / EAPT / EUPT
- BAYONET / MASTERVENT / PLUS / SINGLE POINT

T2 Technology™



The Signature Line of deep-cycle flooded batteries is the flagship of Trojan's product portfolio.

Engineered to provide rugged durability and outstanding performance, Trojan's Signature is perfectly suited for use in renewable energy systems where lowest life-cycle cost is the key consideration. An all-around power house, the Signature Line features Trojan's historically-proven engineering with T2 Technology™, an advanced battery technology for maximum sustained performance, longer life and increased total energy.

MODEL T125
 VOLTAGE 6V
 CAPACITY 240Ah @ 20Hr
 MATERIAL Polypropylene
 BATTERY TYPE Deep Cycle Flooded / Wet Lead Acid Battery

6V
PRODUCT + PHYSICAL SPECIFICATIONS

BCI Group Size	Type	Voltage	Cell(s)	Terminal Type ⁶	Dimensions ^c Inches (mm)			Weight Lbs. (kg)
					Length	Width	Height ^f	
GC2	T-125	6	3	1, 2, 3, 4	10.30 (262)	7.13 (181)	11.15 (283)	66 (30)

ELECTRICAL SPECIFICATIONS

Cranking Performance		Capacity ^A Minutes		Capacity ^B Amp-Hours (AH)				Energy (kWh)	Internal Resistance (mΩ)	Short Circuit Current (amps)
C.C.A. ^D @ 0°F (-18°C)	C.A. ^E @ 32°F (0°C)	@ 25 Amps	@ 75 Amps	5-Hr	10-Hr	20-Hr	100-Hr	100-Hr	—	—
—	—	488	132	195	221	240	266	1.60		

CHARGING INSTRUCTIONS

Charger Voltage Settings (at 77°F/25°C)

System Voltage	6V	12V	24V	36V	48V
Bulk Charge	7.41	14.82	29.64	44.46	59.28
Float Charge	6.75	13.50	27.00	40.50	54.00
Equalize Charge	8.10	16.20	32.40	48.60	64.80

Do not install or charge batteries in a sealed or non-ventilated compartment. Constant under or overcharging will damage the battery and shorten its life as with any battery.

CHARGING TEMPERATURE COMPENSATION

Add	Subtract
0.005 volt per cell for every 1°C below 25°C	0.005 volt per cell for every 1°C above 25°C
0.0028 volt per cell for every 1°F below 77°F	0.0028 volt per cell for every 1°F above 77°F

OPERATIONAL DATA

Operating Temperature	Self Discharge
-4°F to 122°F (-20°C to 50°C) At temperatures below 32°F (0°C) maintain a state of charge greater than 60%	Less than 3% per month depending on storage temperature conditions

STATE OF CHARGE MEASURE OF OPEN-CIRCUIT VOLTAGE

Percentage Charge	Cell	6 Volt
100	2.14	6.42
75	2.09	6.27
50	2.04	6.12
25	1.99	5.97
0	1.94	5.82



Designed in compliance with applicable BCI, DIN, BS and IEC standards. Tested in compliance to BCI and IEC standards.



TROJAN T-125 PERFORMANCE

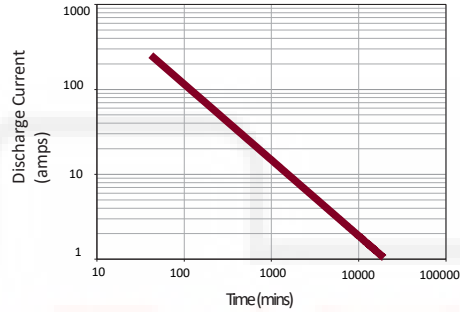

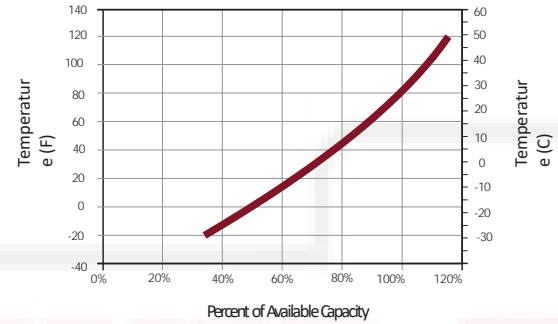

PERCENT CAPACITY VS. TEMPERATURE



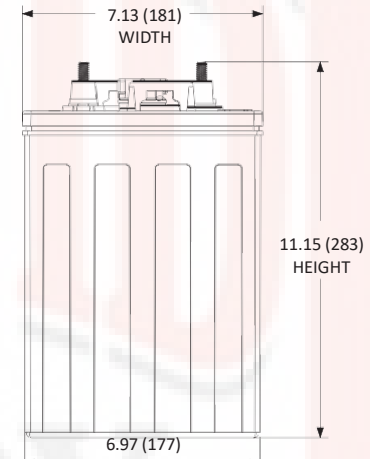
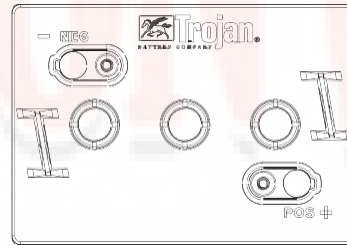
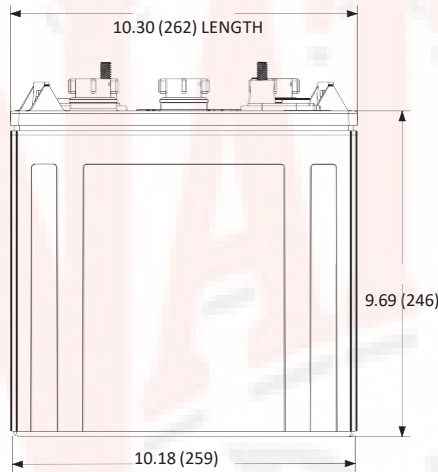

BATTERY DIMENSIONS (shown with EHPT)



TERMINAL CONFIGURATIONS

1	ELPT EMBEDDED LOW PROFILE TERMINAL
	Terminal Height Inches (mm) 1.22 (31) Torque Values in-lb (Nm) 95 – 105 (11 – 12) Bolt 5/16"
2	EHPT EMBEDDED HIGH PROFILE TERMINAL
	Terminal Height Inches (mm) 1.50 (38) Torque Values in-lb (Nm) 95 – 105 (11 – 12) Bolt 5/16"

3	EAPT EMBEDDED AUTOMOTIVE POST TERMINAL
	Terminal Height Inches (mm) 0.95 (24) Torque Values in-lb (Nm) 50 – 70 (5.6 – 7.9)
4	EUPT EMBEDDED UNIVERSAL PROFILE TERMINAL
	Terminal Height Inches (mm) 1.22 (31) Torque Values in-lb (Nm) 95 – 105 (11 – 12) Bolt 5/16"

A. The amount of amp-hours (Ah) a battery can deliver when discharged at a constant rate at 86°F (30°C) for all rates and maintain a voltage above 1.75 V/cell. Capacities are based on peak performance.
 B. Dimensions may vary depending on type of handle or terminal. Batteries should be mounted with 0.5 inches (12.7 mm) spacing minimum.

C. Height taken from bottom of the battery to the highest point on the battery. Heights may vary depending on type of terminal.
 D. Terminal images are representative only.
 E. A boost charge should be performed every 6 months when batteries are in storage.
 F. Weight may vary.